



OGIO® Catalyst Duffel. 95001



Made for the gym or a weekend trip, our modern duffel has ample room to store and organize everything you need.

- 600D rhombus poly/600D poly
- Large main compartment with U-shaped opening
- Side compartment with large mesh window for ventilation
- Detachable, adjustable shoulder strap
- Padded carrying handles
- Front zippered pocket
- Durable, water-resistant bottom
- Dimensions: 10.5”h x 20”w x 10.5”d
- Capacity: 2,200 cu.in./36 L
- Weight: 1.4 lb./0.57 kg

Note: Bags not intended for use by children 12 and under.

The purchase of branded and private label products are subject to certain guidelines. For more information about these requirements, **see our branded and private label sales policies.**

COLOR INFORMATION



Black
PMS NTRBLACKC



Tarmac/Orange
PMS 1655C



Laser Red
PMS 186C



Cobalt Blue
PMS 7686C



OGIO® Catalyst Duffel. 95001

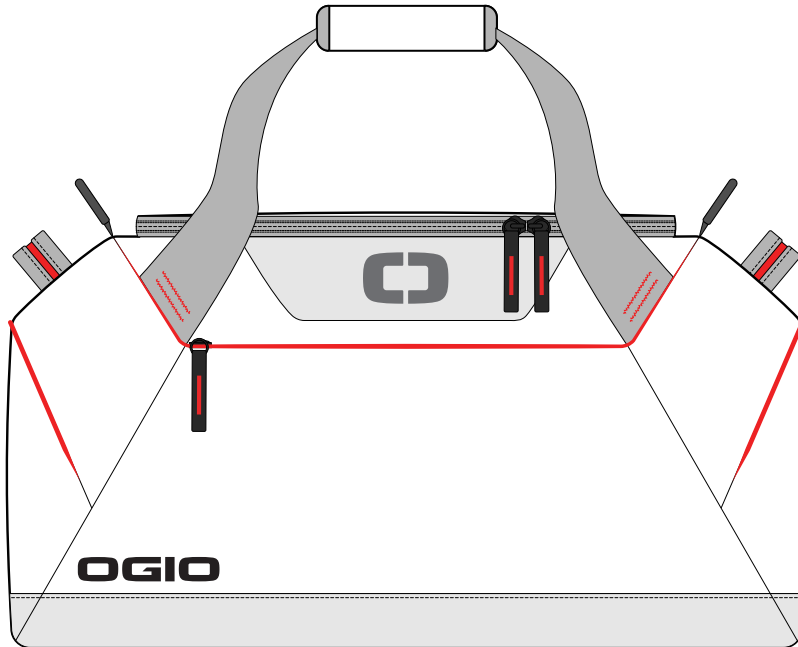

FRONT VIEW

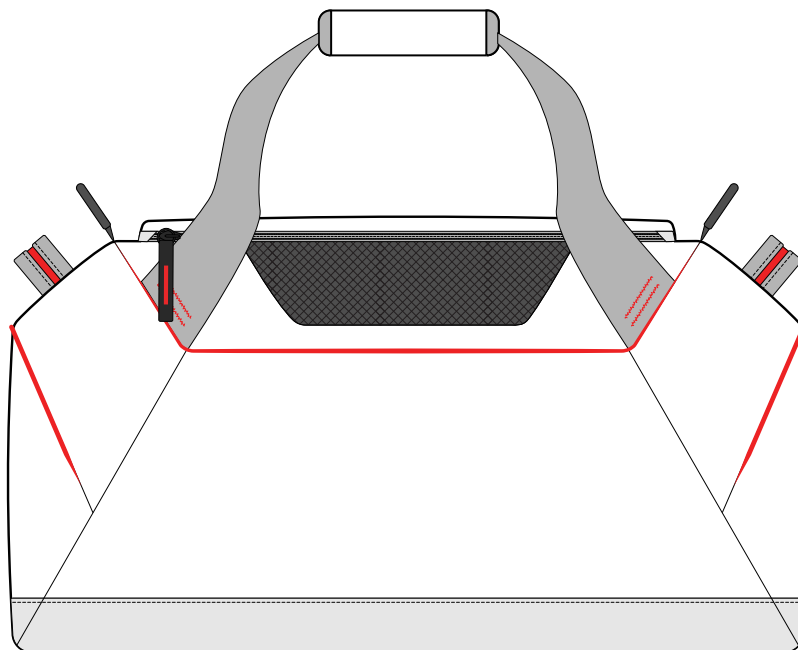

BACK VIEW

Note: Best graphic placement should be per the embellisher/screen printer recommendations.